



Die changing cart RW 600/RWA1000 elmo manually movable or fully electric lifting and moving with docking bar, load capacity up to 1,000 kg



RW 600 elmo "electric motion"



RWA 1000 elmo "electric motion"

Application

Die changing carts facilitate the handling of medium-weight dies and enable dies weighing up to 1,000 kg to be safely transported in an easy and time-saving way.

All cart types are specifically designed for pressing and punching dies as well as for injection and casting moulds.

Description

These special die changing carts are available in double scissor versions with different lifting heights, manually or fully electrically movable, and with a sturdy roller table or as a smooth steel plate. They are made of robust steel and can make tight turns. Thanks to a compact design, all changing carts can be used in tight production spaces.

The combination of a roller table and a battery-powered electric drive offers additional convenience and the safety required when changing dies. The stainless steel table is equipped with sturdy rollers that allow dies to be safely loaded into the press.

Adjustable stops prevent the dies from slipping during transport. The roller table has various holes for several safety bars to optimally prevent dies of different sizes from slipping.

The roller table is equipped with a docking bar for safe transfer of the die to the press.

For transport, the centre of gravity of the load must be positioned in the centre of the cart and the lifting columns must be completely lowered.

Colour: RAL 7021 (dark grey, powder coating), black scissors, stainless steel roller table

Advantages

- Quicker and safer die change
- Precise positioning thanks to docking station
- Electric lifting and moving
- Protection against dies falling off thanks to side rails, front rail, and adjustable insertable bars
- Die-friendly transport
- Secure hold of the die changing lifting table thanks to parking brake

Changing cart versions:

RW 600 elmo "electric motion"

- Up to 1,520 mm table height
- Manual moving
- Electro-hydraulic lifting and lowering
- Load capacity up to 600 kg see page 2

RWA 1000 elmo "electric motion"

- Up to 1,485 mm table height
- Fully electric moving
- Electro-hydraulic lifting and lowering
- Load capacity up to 1,000 kg see page 3

Additional table versions:

see page 6

• Version I

with roller inserts, without lifting function

• Version II

with lowerable rollers and mechanical lifting function

• Version III

with ball inserts, without lifting function

• Version IV

with lowerable hydraulic ball bars + hand pump

• Version V

with swivelling bridge

Accessories

see page 7

Multi-functional drawbar:

- driving switch for continuous and sensitive driving
- Push-button for lifting and lowering
- Toggle switch for two speeds (2 km/h and 4 km/h)
- Safety push-button with stop function
- Signal horn + emergency stop push-button
- Display for battery charge level and service hours counter
- Key switch for on / off



Version RWA 1000 elmo with roller table



Multi-functional drawbar

Die Changing Cart RW 600 elmo

Technical Data • Dimensions

RW 600 elmo "electric motion"

- Double scissor lift up to 1,520 mm table height
- Manual moving
- Electro-hydraulic lifting and lowering
- Roller table
- Docking bar

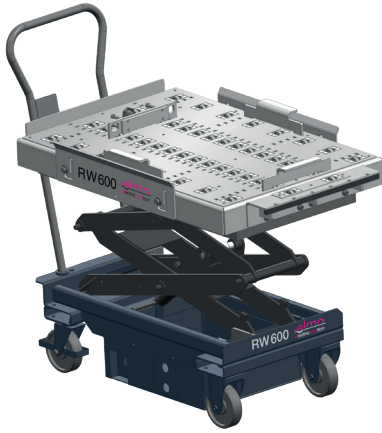

Technical characteristics

Load capacity	[kg]	600 kg
Bed height	[mm]	610–1,520 mm
Brake		on both steering rollers
Wheels		PU
Weight	[kg]	approx. 330
Battery charger		12V, 8A (Built in)
Battery	[Ah]	43
Battery performance		approx. 40 × lift and lower under full load

Optional accessory

For transporting larger dies on the die changing cart, optional side bar extensions can be used.

Extension / side bar

(1 set = 2 pcs.)

Part no. 789160019

Mould / die dimensions

- min. 200 × 200 mm
- max. 1,000 × 700 mm
- max. 1,000 × 900 mm with extension

Operation:

- Push-button for lifting and lowering
- Display for battery state of charge
- without signal horn and key switch

Dimensions

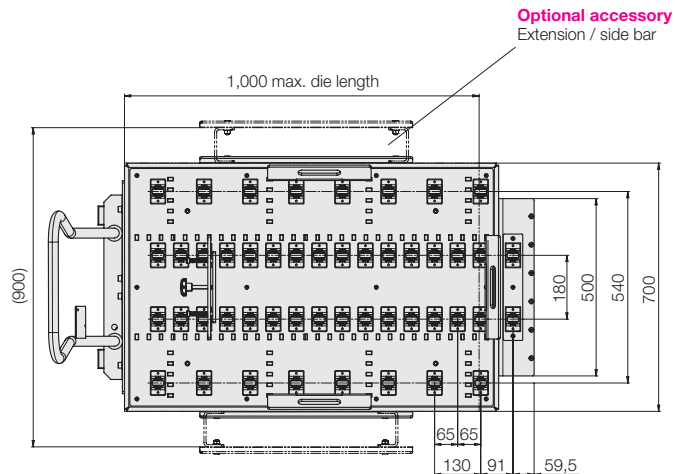
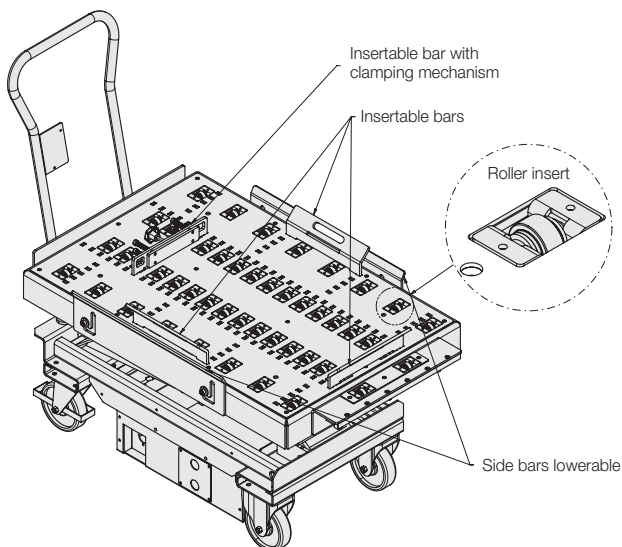
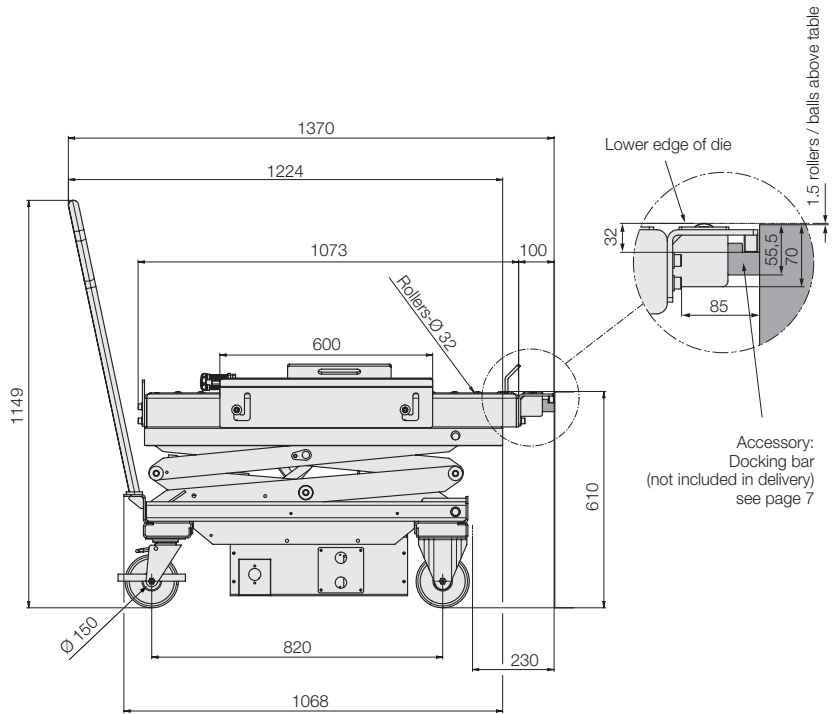
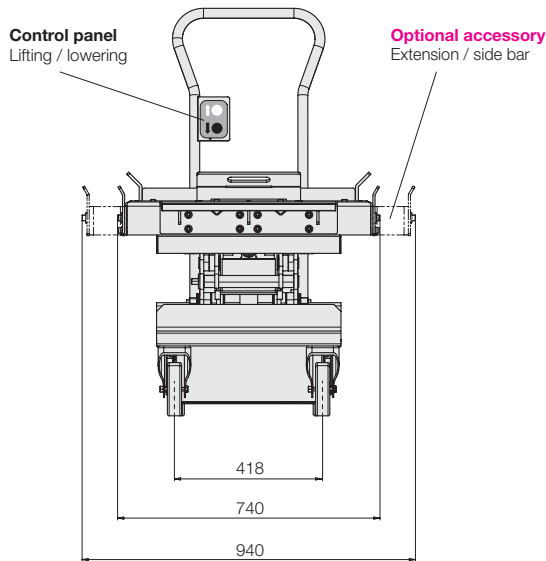

Die changing cart RWA 1000 elmo

Technical data • Dimensions

RWA 1000 elmo "electric motion"

- Double scissor lift up to 1,485 mm table height
- Fully electric moving
- Electro-hydraulic lifting and lowering
- Roller table
- Docking bar

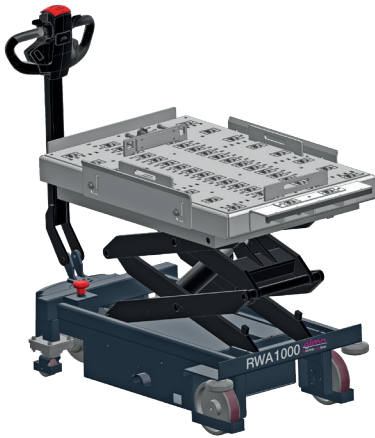

Technical characteristics

Load capacity	[kg]	1,000 kg
Bed height	[mm]	620–1,485
Brake		Motor break
Wheels		PU
Weight	[kg]	approx. 400
Battery charger		24 V, 8 A (Built in)
Battery	[Ah]	50 Ah
Displacement speed	[km/h]	4.0
Creep speed	[km/h]	2.0
Battery performance	[km]	8 (with full load)

Optional accessory

For transporting larger dies on the die changing cart, optional side bar extensions and an extended stop at the back can be used.

Extension, stop at the back

Part no. 520731193

Extension / side bar

(1 set = 2 pcs.)

Part no. 789160019

Mould / die dimensions

min. 200 × 200 mm
 max. 1,000 × 700 mm
 max. 1,000 × 900 mm with extension

Dimensions

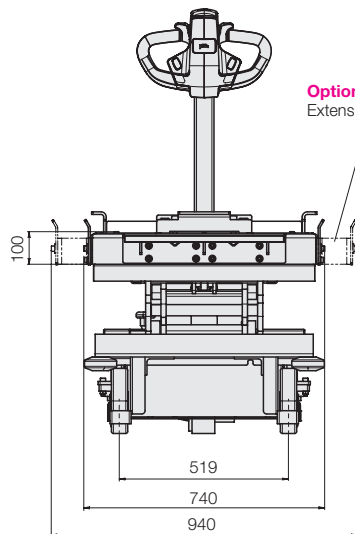

Optional accessory: Extension, stop at the back

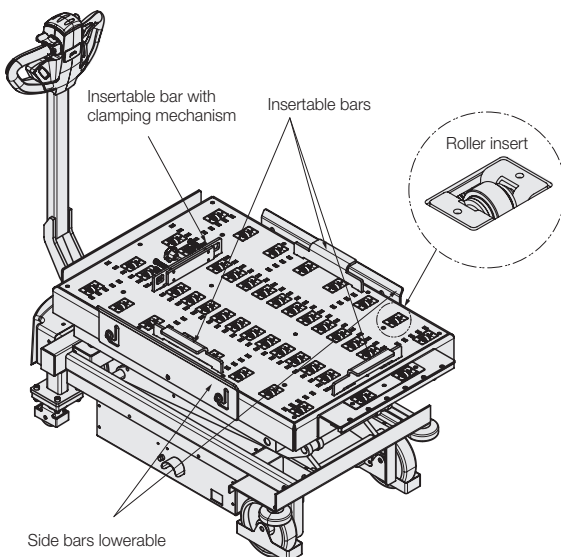
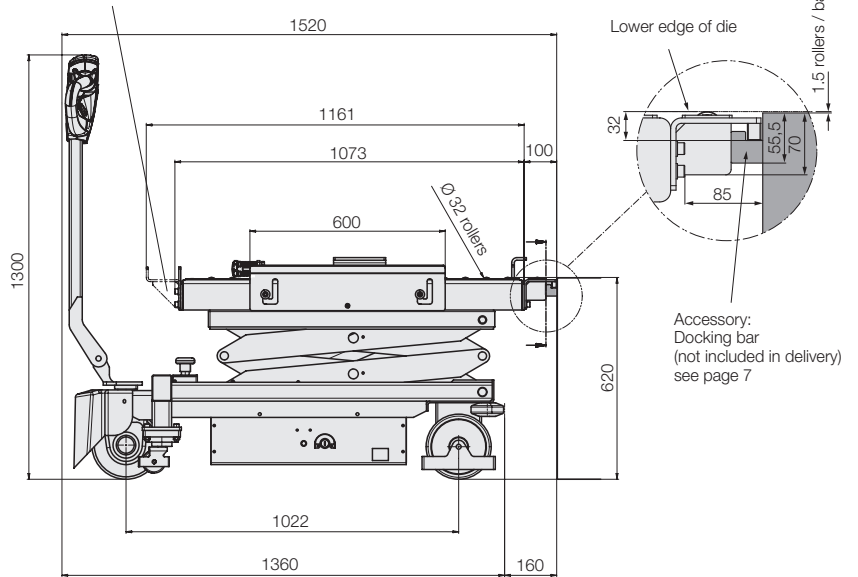

Optional accessory Extension / side bar

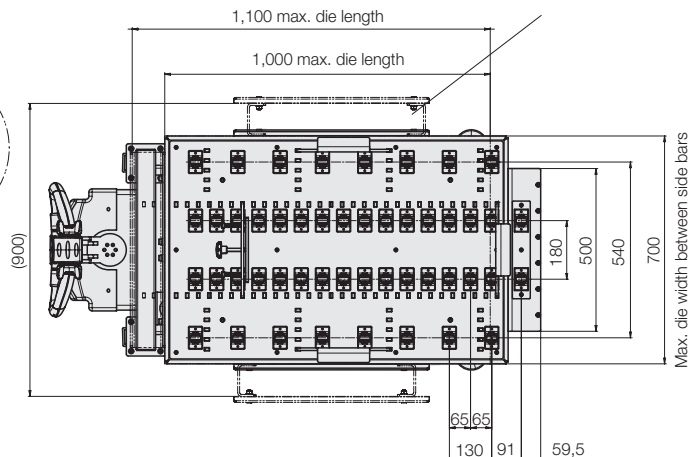

Roller Table Version I with Roller Inserts, without Lifting Function

Version 1

Roller table with roller inserts, without lifting function

In this version, the dies are pushed into the press using fixed roller inserts in the roller table. The dies are secured manually by the operator during transport using adjustable insertable bars.

Docking to the press table provides the optimum entry height and prevents the cart from rolling away.

This version also works without a docking bar on the press table.

RW 600 elmo, With roller table version I

Power supply	Part no.
230 V / 50 Hz	88916 0500
120 V / 60 Hz	88916 1500

RWA 1000 elmo, With roller table version I

Power supply	Part no.
230 V / 50 Hz	88916 0001
120 V / 60 Hz	88916 1001

Dimensions

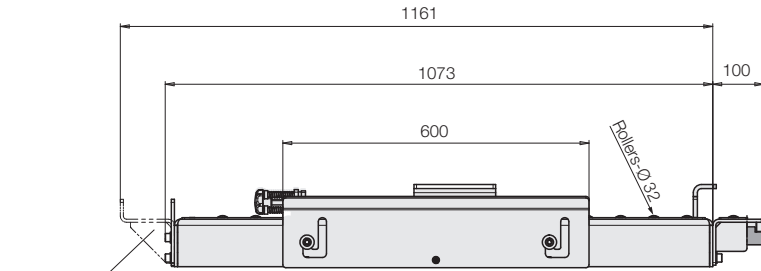

Optional accessory
Extension, stop at the back

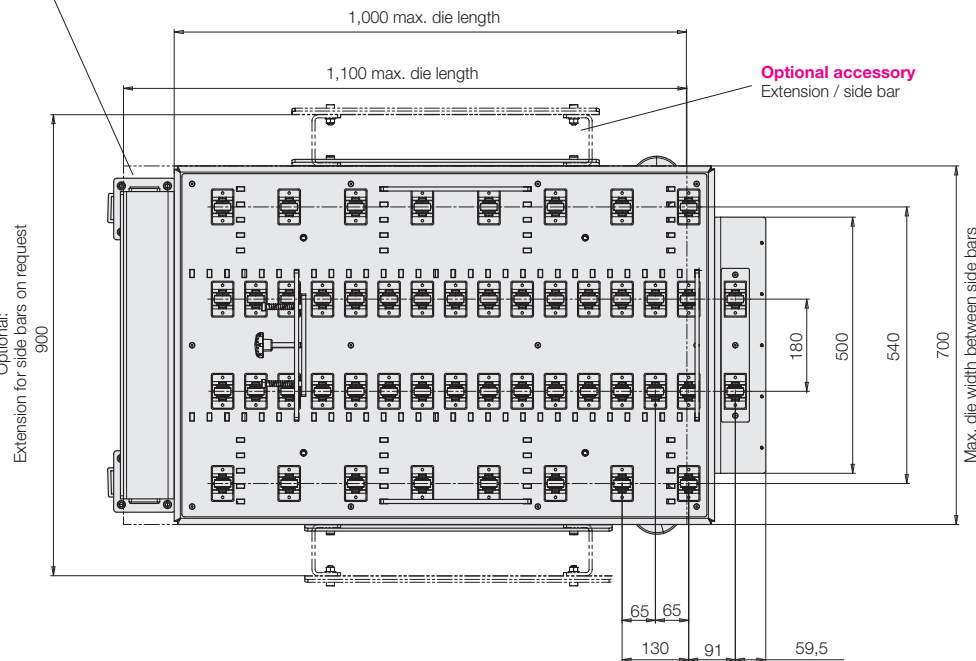

Optional accessory
Extension / side bar

Docking situation

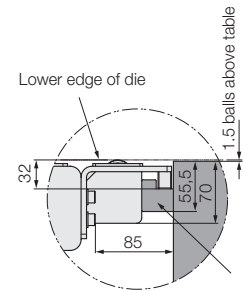

Accessory:
Docking bar
(not included in delivery) see page 7

Optional accessory

For transporting larger dies on the die changing cart, optional side bar extensions can be used.

Extension, stop at the back

Part no. 520731193

Extension / side bar

(1 set = 2 pcs.)

Part no. 789160019

Roller Table Version II

Design with Lowering Rollers and Lifting Function

Version 2

Roller table with lowering rollers and lifting function

In this version, the rollers in the roller table are raised when the changing cart is docked. When the dies are transported, they rest on the platform and are secured against slipping.

The rollers can only be raised by docking to a press table or a rack system. Insertable safety bars on the die changing cart also secure the dies to be transported to prevent them from falling.

This version requires a docking bar on the press table.

RWA 600 elmo, with roller table version II

Power supply	Part no.
230 V/50 Hz	889160600
120 V/60 Hz	889161600

RWA 1000 elmo, with roller table version II

Power supply	Part no.
230 V/50 Hz	889160100
120 V/60 Hz	889161100

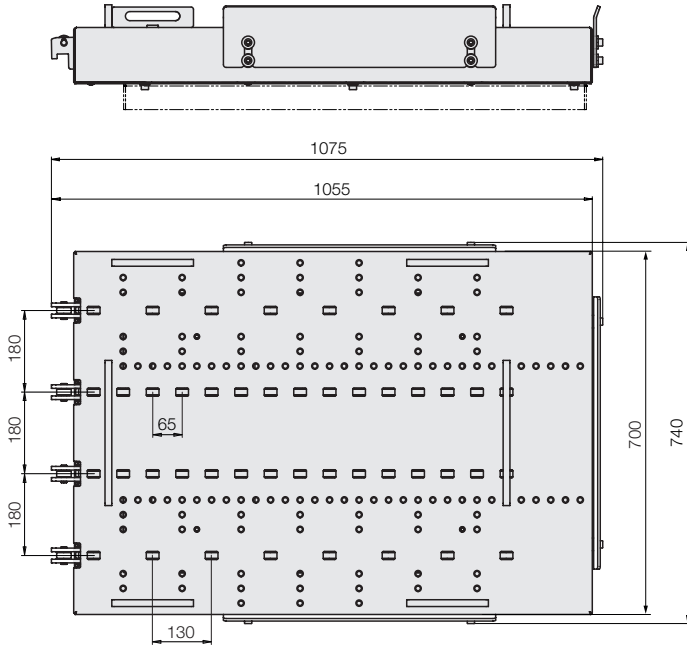

The rollers are raised during docking. The die can be moved.



The rollers are lowered during transport. The die rests securely on the platform.

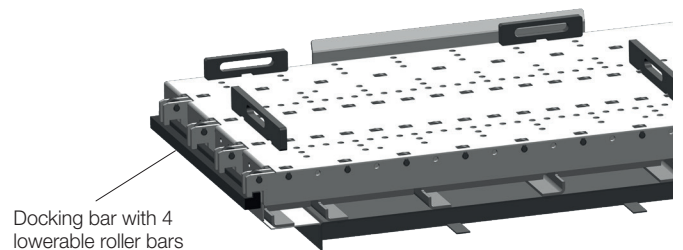

Version III
with ball inserts, without lifting function

In this version, the dies are pushed into the press using fixed ball inserts in the ball table. The dies are secured manually by the operator during transport using adjustable insertable bars.

Docking to the press table provides the optimum entry height and prevents the cart from rolling away.

This version also works without a docking bar on the press table.

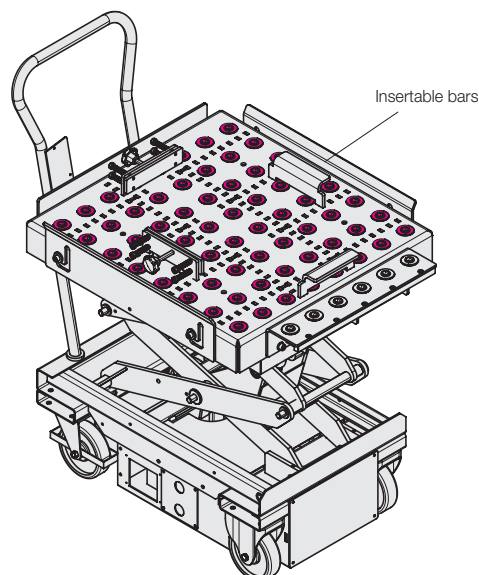

Version IV
with lowerable hydraulic ball bars and hand pump

In this version, the built-in hydraulic ball bars in the die changing table are raised using a separate hydraulic hand pump. The dies are secured manually by the operator during transport using adjustable insertable bars.

This version also works without a docking bar on the press table.

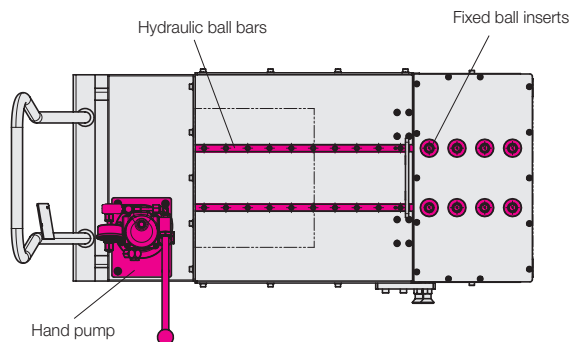

Version V
with swivelling bridge

RW 600 and RWA 1000 elmo are available as versions with an attached bridge. The changing table is equipped at the front with a bridge and docking bar for docking onto the press bed. This makes it easy to bridge over colliding edges on the press table.

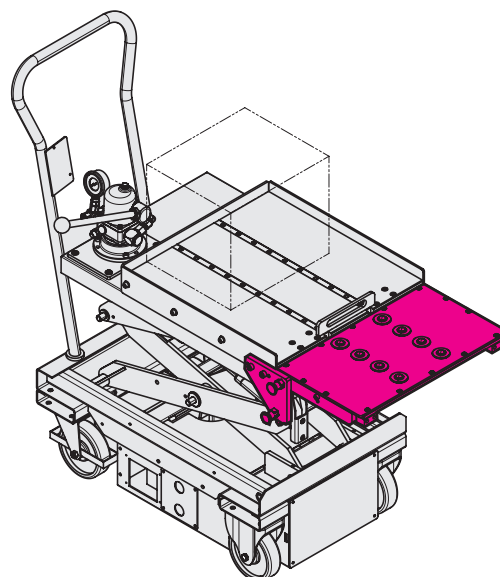

Accessories

Docking bars on the press

To achieve the precise insertion height on the press table, the press table is fitted with screw-in docking bars. A docking bar on the changing cart is included in our delivery.

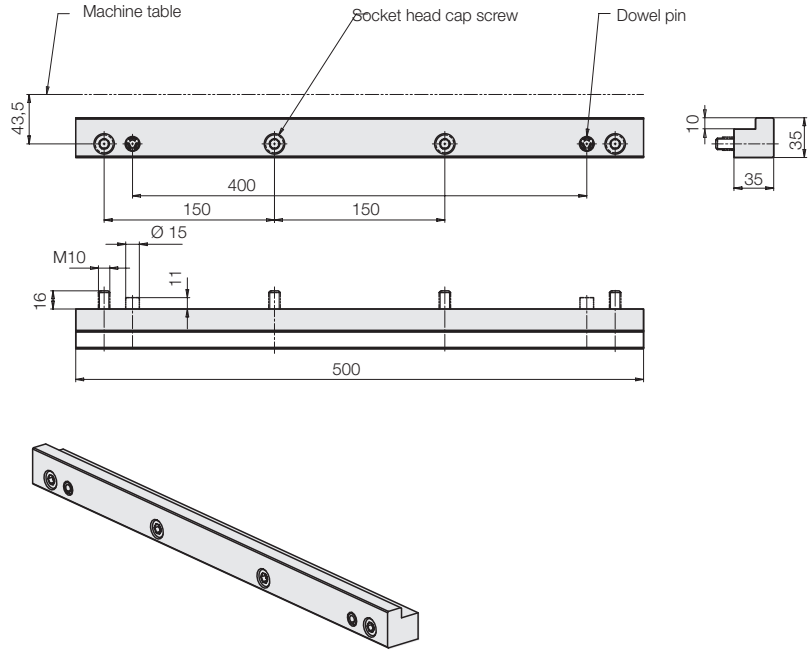

Docking bar, one-piece

Part no.

Length 500 mm 789140003

Length 600 mm 789140009

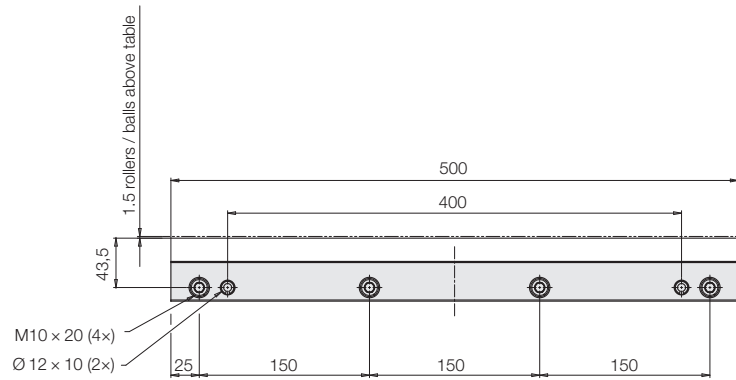

Docking bar, two-piece (1 set= 2 bars)

Part no.

Length 500 mm 789140010

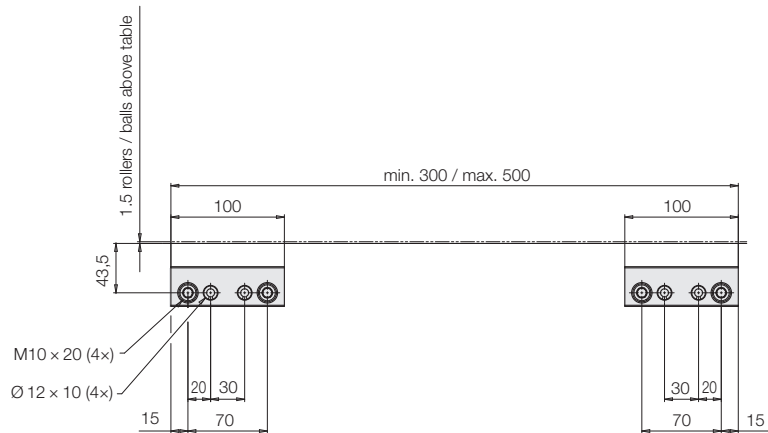

Additional accessories on request:

- Ram protection and die insert slope anchored to floor
- Acoustic or visual tilt indicator